



R-600

INSTALLATIONS MANUAL (DK)
INSTALLATIONSANLEITUNG (DE)
INSTALLATION MANUAL (UK)
MANUEL D'INSTALLATION (FR)
INSTALLASJONSHÅNDBOK (NO)
INSTALLATIONS MANUAL (SE)
ASENNUSKÄSIKIRJA (FIN)
INSTALLATIE HANDLEIDING (NL)

CONTENTS

Installation manual		2
In general		3
Chimney		3
Technical data		4
Specifications		4
Dimensional sketches		5
Information plate		9
Installation		11
Delivery packaging		11
Choice of material for installation		12
Installation dimensions	600-1	13
Installation distance	600-1	14
Installation dimensions	600-2	16
Installation distance	600-2	17
Installation dimensions	600-3	20
Installation distance	600-3	21
Adjustable feet		25
Service hatch		26
Heat distributor		27
External air connection		28
Fitting the floor plate		30
Lubricating hinges		31
Combustion chamber lining		32
Cleaning the flue		33
Additional convection openings		35
Spare part drawing		39
Spare parts list		40
Performance declaration		41
Test certificate		42
The Clean Air Act		45

INSTALLATION MANUAL

Congratulations on the acquisition of your new RAIS or ATTIKA product! This installation manual will ensure that your fireplace insert is installed correctly and that it will provide you with comfort and pleasure for many years to come.

IN GENERAL

It is important that the fire-place insert is correctly installed, in consideration of the environment and people's safety.

The installation must comply with all local rules and regulations, including those that refer to national and European standards. A certified chimney sweeper should be contacted before the installation is started.

No unauthorised alterations may be made to the fireplace insert.

GENERAL INSTALLATION REQUIREMENTS

Before the fireplace insert may be taken into use the installation must be reported to your local chimney sweeper.

There must be a plentiful supply of fresh air in the installation room to ensure good combustion – if required, through an AirSystem connection. NB: Any mechanical air extraction, for example a cooker hood, can minimise the supply of air. Any air vent must be positioned in a way that ensures the supply of air cannot be blocked.

The fireplace insert has an air consumption of 10–20 m³/h.

The floor structure must be able to support the weight of the fireplace insert and a chimney, if required. If the existing floor structure does not meet this requirement, suitable measures must be taken (e.g. installation of a load distribution plate). If in doubt, contact a building expert.

National and local regulations must be complied with, including the size of the non-flammable plate that must cover the flammable floor in front of the fireplace insert to protect the floor from fallen embers.

The fireplace insert must be positioned at a safe distance from flammable material. Due to the risk of fire, flammable items (e.g. furniture) may not be positioned closer to the fireplace insert than the closest permitted distance stated in the installation section. When deciding where you shall install your RAIS/ATTIKA fireplace insert, you should think about being able to heat other rooms in the home, so you get the most out of your new fireplace insert.

When your fireplace insert is delivered, please check it for any defects.

CHIMNEY

The chimney must be high enough to ensure that the chimney draught conditions are correct, i.e. –14 to –18 pascal. If the recommended chimney draught cannot be achieved, problems from smoke escaping from the door may arise when lighting the fire. We recommend that the chimney is adapted to suit the flue outlet spigot. The flue outlet spigot is 150 mm in diameter.

If the draught is excessive, it is recommended that you equip the chimney with a regulating damper. If a regulating damper is fitted, you must ensure that there is a free flow area of at least 20 cm² at the closed regulating damper.

Remember that there must be free access to the access door on the chimney.

The length of the chimney, calculated from the top of the fireplace insert should not be less than 3 m and must be at least 80 cm above the roof ridge. If the chimney is installed at the side of the house, the top of the chimney must never be lower than the roof ridge or the roof's highest point.

Note that there are often national and local regulations relating to houses with thatched roofs.

The fireplace insert is suitable for connecting to a shared flue but we recommend that the in-feed is positioned so that there is a free-height difference between them of at least 250 mm.

NB!

RAIS/ATTIKA recommends that the fireplace insert is installed by an authorised technician. Please ask your dealer for further information.

TECHNICAL DATA

SPECIFICATIONS			
Danish Technological Institute ref.: 300-ELAB-2431-EN			
	RAIS 600-1	RAIS 600-2	RAIS 600-3
Nominal output (kW)	5.8	5.8	5.8
Min./max. output (kW)	4 - 8 *	4 - 8 *	4 - 8 *
Heating area (m ²)	120	120	120
Fireplace insert width/depth/height (mm)	720 X 402 X 610	699 X 402 X 610	678 X 402 X 610
Combustion chamber W x D x H (mm)	544 X 255 X165 **	544 X 255 X165 **	544 X 255 X165 **
Min. uptake (pascal)	-12	-12	-12
Weight (kg) min., dependent on model	99	99	99
Efficiency (%)	76	76	76
CO emission attributed to 13% O ₂ (%)	0.0915 (1144 mg/Nm ³)	0.0915 (1144 mg/Nm ³)	0.0915 (1144 mg/Nm ³)
NOx emission attributed to 13% O ₂ (mg/Nm ³)	69	69	69
OGC emission attributed to 13% O ₂ (mg/Nm ³)	54	54	54
Particle emission in accordance with NS3058/3059 (g/kg)	2.11	2.11	2.11
Dust measurement in accordance with DIN + O ₂ (mg/Nm ³)	5	5	5
Flue gas flow (g/s)	6.1	6.1	6.1
Flue gas temperature (°C)	306	306	306
Calculated flue gas temperature (°C) at spigot	367	367	367
Recommended amount of wood (kg) when stoking the fire (Distributed between two logs, each max. 24 cm)	1.5	1.5	1.5
Intermittent operation	Stoking should be done within 50 minutes	Stoking should be done within 50 minutes	Stoking should be done within 50 minutes

*Not verified by test.

**Max. load

The fireplace insert is tested and approved by:

DTI
 Danish Technological Institute
 Teknologiparken Kongsvang Allé 29
 8000 Aarhus C
 Denmark
 www.dti.dk
 Tel.: +45 72 20 20 00
 Fax: +45 72 20 10 19

600-1

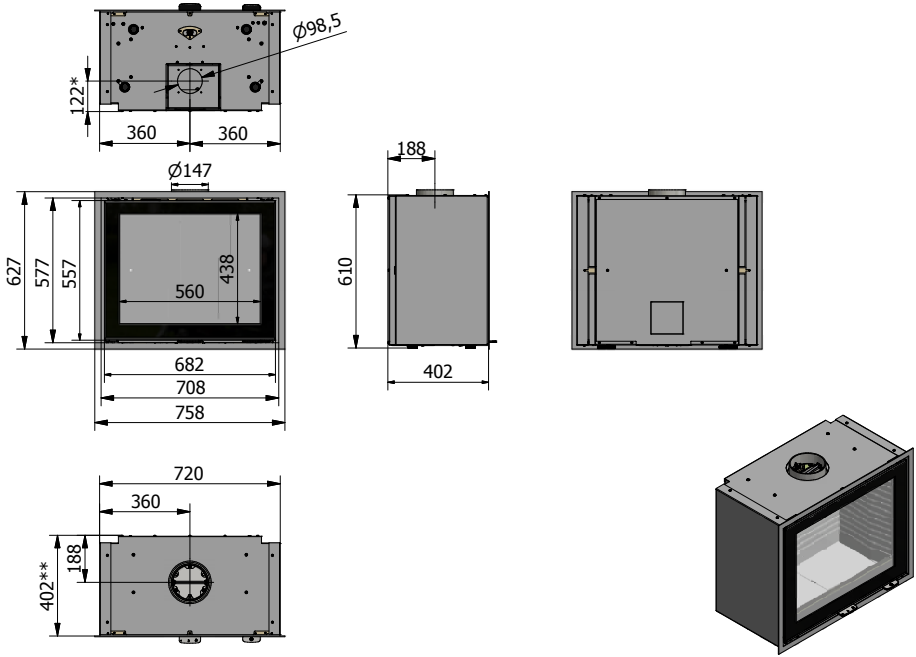

* AirSystem

** Interior dimensions

600-2 (right)

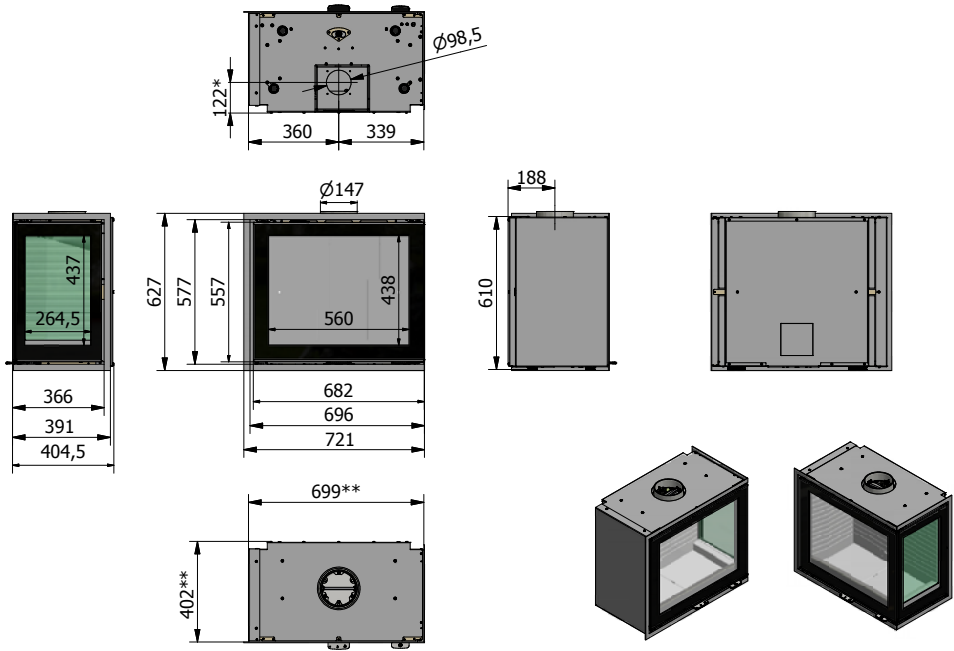

* AirSystem

** Interior dimensions

600-2 (left)

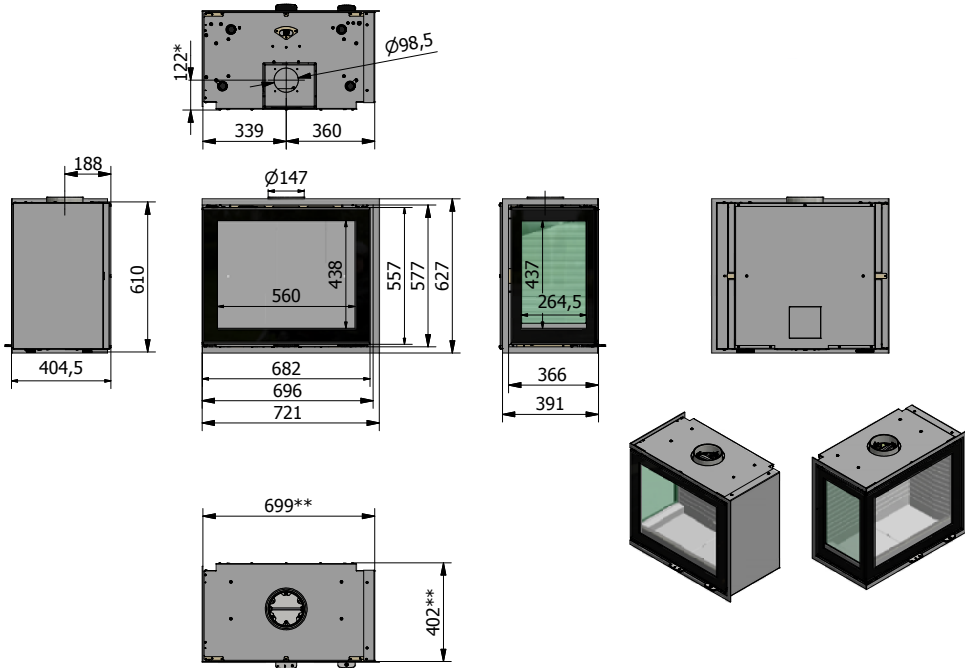

* AirSystem

** Interior dimensions

All dimensions are in mm.

600-3

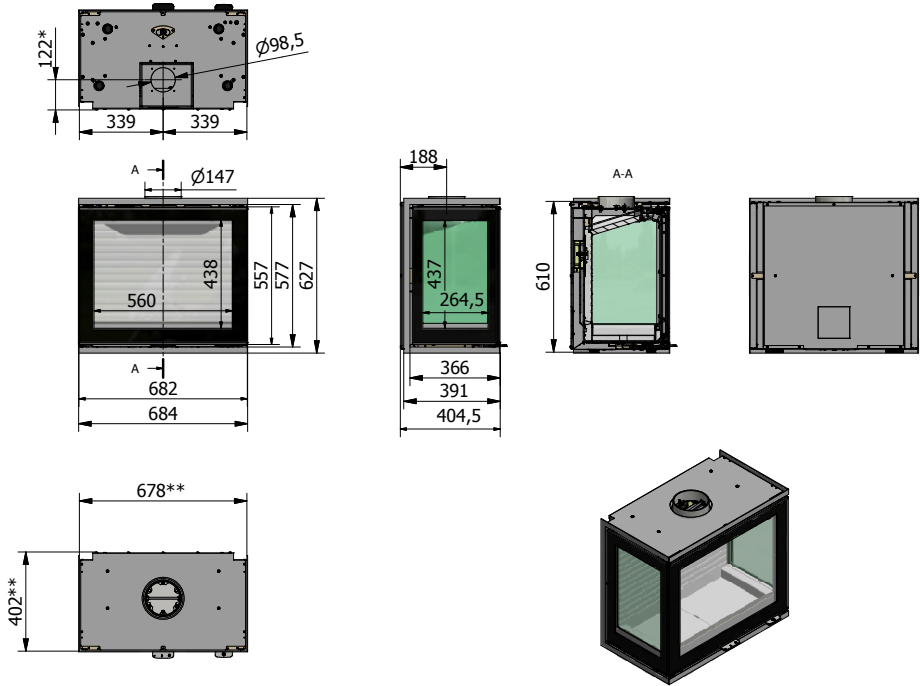

* AirSystem

** Interior dimensions

INFORMATION PLATE

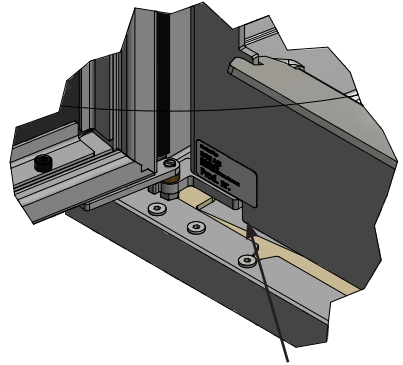

All RAIS/ATTIKA fireplace inserts have an information plate which states the stove's distance from flammable materials, efficiency, etc. The information plate is laid loose in the fireplace insert on delivery.





The production number is located in the bottom left corner of the fireplace insert. See drawing.

And at the front of the installation guide.

Information plate 600-1

21	
EN 13229:2001+A1:2003+A2:2004, EC.NO: 11 Notified Body: 1235	
 	
Produced at: RAIS A/S, Industrivej 20, 9900 Frederikshavn, Danmark	
Rais 600 Front model, Rais 600 Classic Front model	
AFSTAND TIL BRÆNDBART, BAG/VEG ABSTAND ZU BRENNBAREN BAUTEILEN, HINTEN DISTANCE TO COMBUSTIBLE BACK WALL DIST. ENTRE COMPOSANTS COMBUSTIBLES, ARRIÈRE	DK: mm SE BRUGERVEJLEDNING DE: mm SIEHE BEDIENUNGSANLEITUNG UK: mm SEE USER MANUAL FR: mm CONSULTEZ LE GUIDE DE L'UTILISATEUR
AFSTAND TIL BRÆNDBART, SIDEVEG ABSTAND ZU BRENNBAREN BAUTEILEN, SEITE DISTANCE TO COMBUSTIBLE SIDE WALL DISTANCE ENTRE COMPOSANTS COMBUSTIBLES, CÔTÉ	DK: 350 mm SE BRUGERVEJLEDNING DE: 350 mm SIEHE BEDIENUNGSANLEITUNG UK: 350 mm SEE USER MANUAL FR: 350 mm CONSULTEZ LE GUIDE DE L'UTILISATEUR
AFSTAND TIL BRÆNDBART, MØBLERING ABSTAND VORNE ZU BRENNBAREN MÖBELN DISTANCE TO FURNITURE AT THE FRONT DISTANCE ENTRE COMPOSANTS COMBUSTIBLES, DEVANT	DK: 1100 mm SE BRUGERVEJLEDNING DE: 1100 mm SIEHE BEDIENUNGSANLEITUNG UK: 1100 mm SEE USER MANUAL FR: 1100 mm CONSULTEZ LE GUIDE DE L'UTILISATEUR
CO EMISSION (REL. 13% O ₂) CO EMISSION IN DEN VERBRENNUNGSPRODUKTEN (BEI 13%O ₂) EMISSION OF CO IN COMBUSTION PRODUCTS (AT 13%O ₂) EMISSION CO DANS LES PRODUITS COMBUSTIBLES (À 13%O ₂)	0,0915 % / 1144 mg/Nm ³
STØV / STAUB / DUST / POUSSIÈRES:	5 mg/Nm ³
RØGGASTEMPERATUR / ABGASTEMPERATUR / FLUE GAS TEMPERATURE / TEMPÉRATURE DES GAZ DE FUMÉE:	306 °C
NOMINEL EFFEKT / HEIZLEISTUNG / THERMAL OUTPUT / PUISSANCE CALORIFIQUE:	5,8 kW
VIRKNINGSGRAD / ENERGIEEFFIZIENZ / ENERGY EFFICIENCY / EFFICACITÉ ÉNERGÉTIQUE:	76 %
DK: Brug kun anbefalede brændsler. Følg instrukserne i bruger manualen. Anordningen er egnet til røggasafledning og intervalfyring. DE: Lesen und befolgen Sie die Bedienungsanleitung. Zeitbrandfeuerstätte. Nur empfohlene Brennstoffe einsetzen. UK: Fuel types (only recommended). Follow the installation and operating instruction manual. Intermittent operation. F: Veuillez lire et observer les instructions du mode d'emploi. Foyer à durée de combustion limitée, homologué pour cheminée à connexions multiples. Utiliser seulement les combustibles recommandés.	DK: BRÆNDE DE: HOLZ UK: WOOD FR: BOIS
Not to be used in a shared flue	Raumheizer für feste Brennstoffe Appliance fired by wood Poêle pour combustibles solides
Produced for: ATTIKA FEUER AG, Brunnmatt 16, CH-6330 Cham / RAIS A/S, Industrivej 20, DK-9900 Frederikshavn	

Information plate 600-2 and 600-3

19	
EN 13229:2001+A1:2003+A2:2004, EC:NO:11 Notified Body: 1235	
 	
Produced at: RAIS A/S, Industrivej 20, 9900 Frederikshavn, Danmark	
Rais 600 Right model, Rais 600 Left model, Rais 600 3 Side model Rais 600 Classic Right model, Rais 600 Classic Left model, Rais 600 Classic 3 Side model	
AFSTAND TIL BRÆNDBART, BAGVEG ABSTAND ZU BRENNBAREN BAUTEILEN, HINTEN DISTANCE TO COMBUSTIBLE BACK WALL DIST. ENTRE COMPOSANTS COMBUSTIBLES, ARRIÈRE AFSTAND TIL BRÆNDBART, SIDEVEG ABSTAND ZU BRENNBAREN BAUTEILEN, SEITE DISTANCE TO COMBUSTIBLE SIDE WALL DISTANCE ENTRE COMPOSANTS COMBUSTIBLES, CÔTÉ AFSTAND TIL BRÆNDBART, MØBLERING ABSTAND VORNE ZU BRENNBAREN MÖBELN DISTANCE TO FURNITURE AT THE FRONT DISTANCE ENTRE COMPOSANTS COMBUSTIBLES, DEVANT CO EMISSION (REL. 13% O2) CO EMISSION IN DEN VERBRENNINGSPRODUKTEN (BEI 13%O2) EMISSION OF CO IN COMBUSTION PRODUCTS (AT 13%O2) EMISSION CO DANS LES PRODUITS COMBUSTIBLES (À 13%O2) STØV / STAUB / DUST / POUSSIÈRES: RØGGASTEMPERATUR / ABGASTEMPERATUR / FLUE GAS TEMPERATURE / TEMPÉRATURE DES GAZ DE FUMÉE: NOMINEL EFFEKT / HEIZLEISTUNG / THERMAL OUTPUT / PUISSANCE CALORIFIQUE: VIRKNINGSGRAD / ENERGIEEFFIZIENZ / ENERGY EFFICIENCY / EFFICACITÉ ÉNERGÉTIQUE: DK: Brug kun anbefalede brændsler. Følg instruktørerne i bruger manualen. Anordningen er egnet til røggasafledning og intervalfyring. DE: Lesen und befolgen Sie die Bedienungsanleitung. Zeitbrandfeuerstätte. Nur empfohlene Brennstoffe einsetzen. UK: Fuel types (only recommended). Follow the installation and operating instruction manual. Intermittent operation. F: Veuillez lire et observer les instructions du mode d'emploi. Foyer à durée de combustion limitée, homologué pour cheminée à connexions multiples. Utiliser seulement les combustibles recommandés.	DK: mm SE BRUGERVEJLEDNING DE: mm SIEHE BEDIENUNGSANLEITUNG UK: mm SEE USER MANUAL FR: mm CONSULTEZ LE GUIDE DE L'UTILISATEUR DK: 500mm SE BRUGERVEJLEDNING DE: 500mm SIEHE BEDIENUNGSANLEITUNG UK: 500mm SEE USER MANUAL FR: 500mm CONSULTEZ LE GUIDE DE L'UTILISATEUR DK: 950mm SE BRUGERVEJLEDNING DE: 950mm SIEHE BEDIENUNGSANLEITUNG UK: 950mm SEE USER MANUAL FR: 950mm CONSULTEZ LE GUIDE DE L'UTILISATEUR 0,0915 % / 1144 mg/Nm ³ 5 mg/Nm3 306 °C 5,8 kW 76 % DK: BRÆNDE DE: HOLZ UK: WOOD FR: BOIS Raumheizer für feste Brennstoffe Appliance fired by wood Poêle pour combustibles solides
Not to be used in a shared flue	
Produced for: ATTIKA FEUER AG, Brunnmatt 16, CH-6330 Cham / RAIS A/S, Industrivej 20, DK-9900 Frederikshavn	

INSTALLATION

The following section explains how to install the fireplace insert and includes information about the packaging, installation distances, etc.

DELIVERY PACKAGING

The fireplace insert is supplied secured to a transport pallet using four transport safety fittings.

The safety fittings are secured with screws and these must be removed. The safety fitting can then be removed.

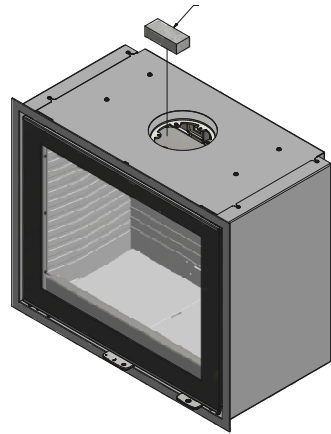
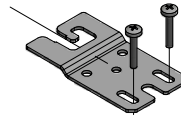
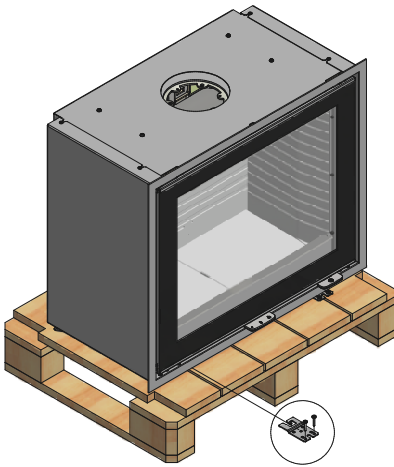

There is a polystyrene block in the top of the fireplace insert which secures the baffle during transport. The polystyrene block must be removed before starting a fire in the stove.

DISPOSAL

RECYCLING OF PACKAGING

The fireplace insert is delivered in packaging that can be recycled.

This packaging must be disposed of in accordance with national regulations relating to the disposal of waste.

NB: DISPOSAL OF THE FIREPLACE INSERT AT THE END OF ITS LIFETIME

The glass cannot be recycled.

The glass must be disposed of along with any ceramics or porcelain waste. Heat-resistant glass has a higher melting point and therefore cannot be recycled.

By ensuring heat-resistant glass does not end up alongside recyclable products you are making an important contribution to the environment.

INSTALLATION

CHOICE OF MATERIAL FOR INSTALLATION

The material can be panels/brick with an insulation value greater than $0.03 \text{ m}^2 \times \text{K/W}$. The insulation is defined as wall thickness (in metres) divided by the wall's Lambda value.

Contact your installation technician/chimney inspector.

During testing, the fireplace insert is installed in a cabinet made from non-flammable 50 mm calcium silicate panels (Skamotec 225).

The fireplace insert must be installed in heat-resistant material.

See the following pages for the installation dimensions and the installation distances for 600-1, 600-2 and 600-3.

UK



INSTALLATION DIMENSIONS: 600-1

Applies to installations made from non-flammable panels.

Cavity dimensions (height x width) min. 615 x 730 mm

A fireplace insert may never be installed in a cavity that is tight, since steel expands when heated.

UK

The minimum area for convection air above and below the fireplace insert can be distributed for several cavities.

500 cm²

250 cm²

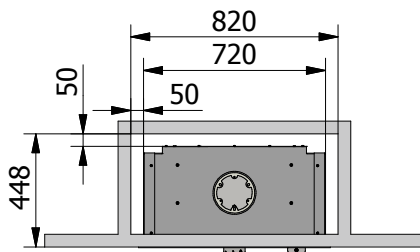
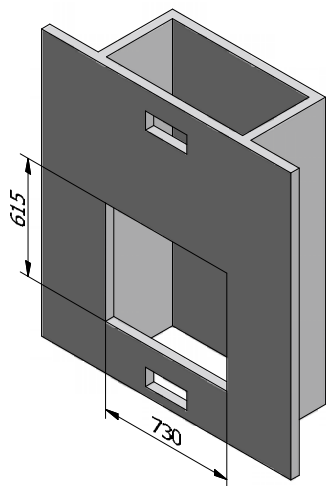
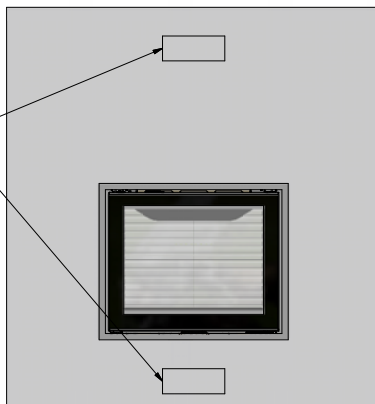

INSTALLATION DISTANCE TO COMBUSTIBLE MATERIAL INSULATED CHIMNEY

INSTALLATION DISTANCE: 600-1

A non-flammable panel must be fitted directly above the convection opening so that “standing” hot air does not develop above the convection opening. This is done to protect the ceiling and to transport the heat out of the fireplace insert.

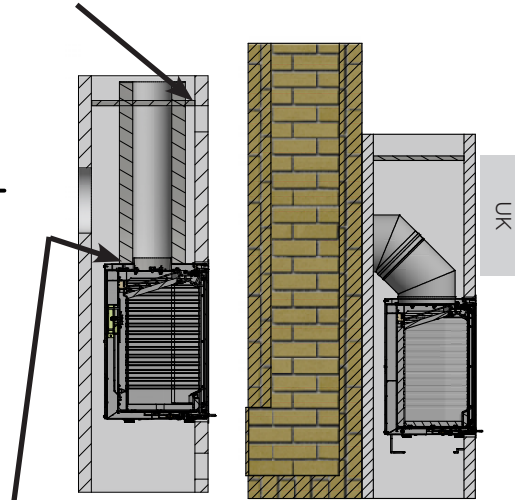
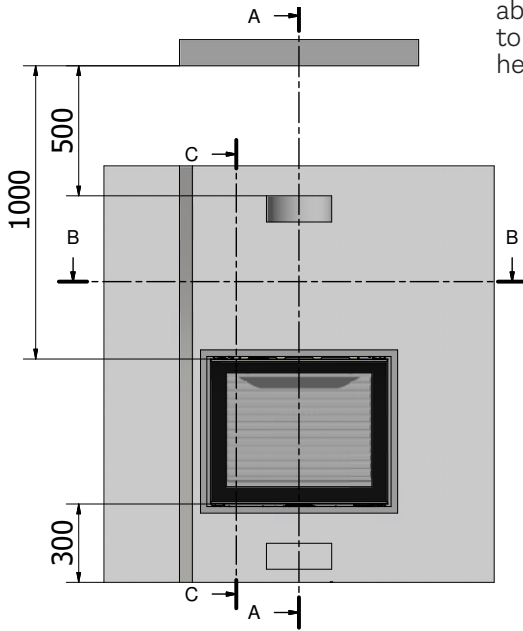

The insulated part of the chimney must extend all the way down to the flue spigot. Also applies if a bended pipe is used into an existing chimney (see drawing)

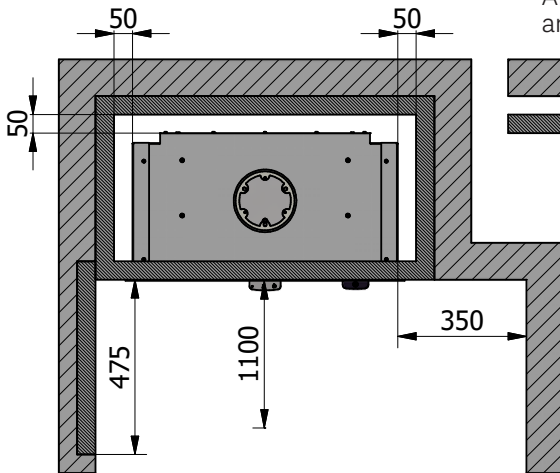

- Flammable wall
- Non-flammable plate

DISTANCE FROM	DISTANCE IN MM
Furniture to door	1100
Internal distance to cabinet	50
Ceiling to door top edge	1000
Ceiling from convection opening	500
Floor to door bottom edge	300
Flammable at side of door	350
Firewall extension	475

If the side distance of 350mm cannot be observed, the first 475mm must be made of non-combustible plate.

INSTALLATION DISTANCE TO COMBUSTIBLE MATERIAL UN-INSULATED CHIMNEY

INSTALLATION DISTANCE: 600-1

A non-combustible plate must be fitted directly above the convection opening, so that "standing" hot air does not occur above the convection opening. This is done to protect the ceiling and direct the hot air out of the cassette.

The insulated part of the chimney must pass through the non-combustible board!

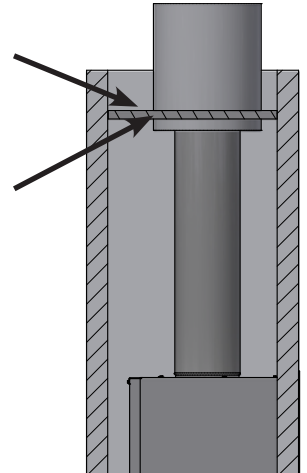

When an uninsulated chimney is used, the three convection openings must be opened. see the section: Additional convection openings

When using an uninsulated chimney, a cavity of 50 mm must be created with stagnant air between the built-in box and the combustible wall before the safety distances apply.

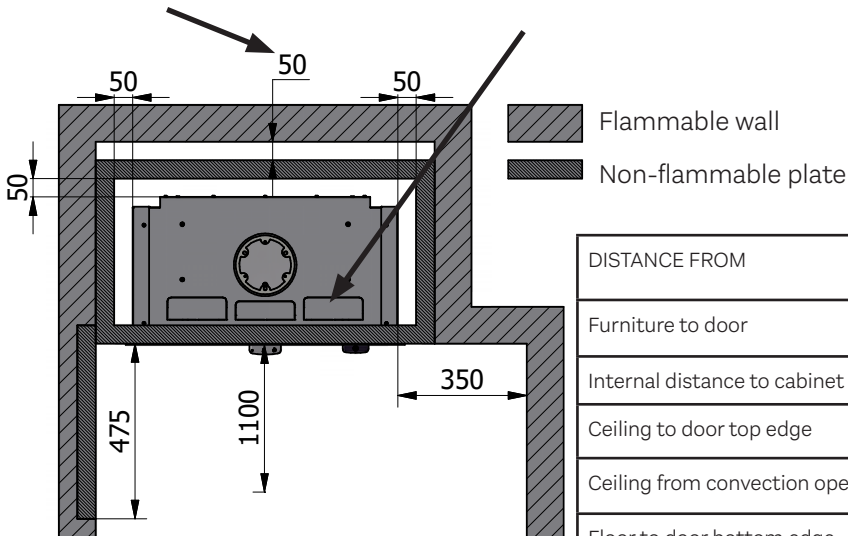

DISTANCE FROM	DISTANCE IN MM
Furniture to door	1100
Internal distance to cabinet	50
Ceiling to door top edge	1000
Ceiling from convection opening	500
Floor to door bottom edge	300
Flammable at side of door	350
Firewall extension	475
Cavity behind built-in box	50

If the side distance of 350mm cannot be observed, the first 475mm must be made of non-combustible plate.

INSTALLATION DIMENSIONS: 600-2

Applies to installations made from non-flammable panels.

Cavity dimensions (height x width) min. 615 x 704 x 375 mm

A fireplace insert may never be installed in a cavity that is tight, since steel expands when heated.

The minimum area for convection air above and below the fireplace insert can be distributed for several cavities.

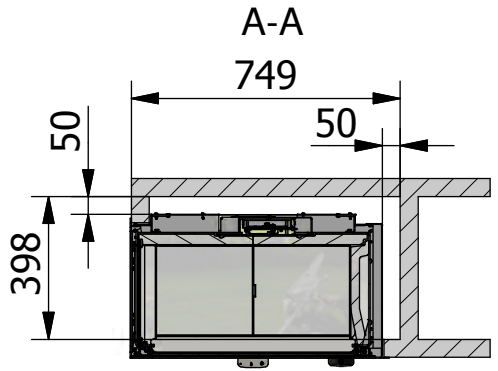
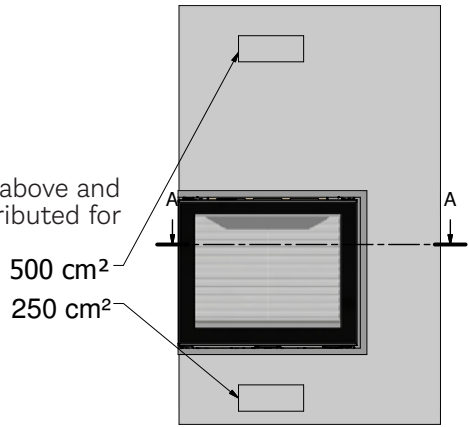
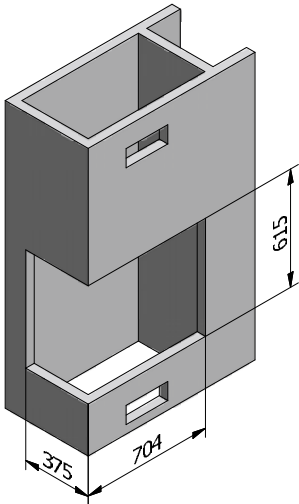

INSTALLATION DISTANCE TO COMBUSTIBLE MATERIAL INSULATED CHIMNEY

INSTALLATION DISTANCE: 600-2

A non-flammable panel must be fitted directly above the convection opening so that “standing” hot air does not develop above the convection opening. This is done to protect the ceiling and to transport the heat out of the fireplace insert.

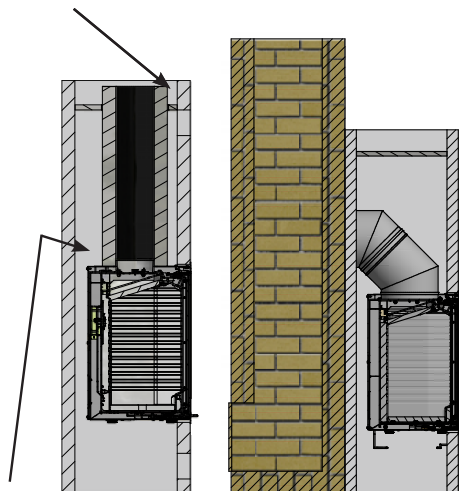
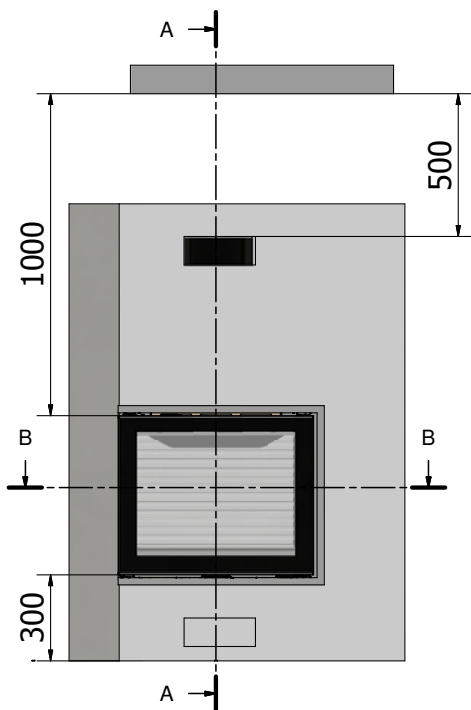

The insulated part of the chimney must extend all the way down to the flue spigot. Also applies if a bended pipe is used into an existing chimney (see drawing)

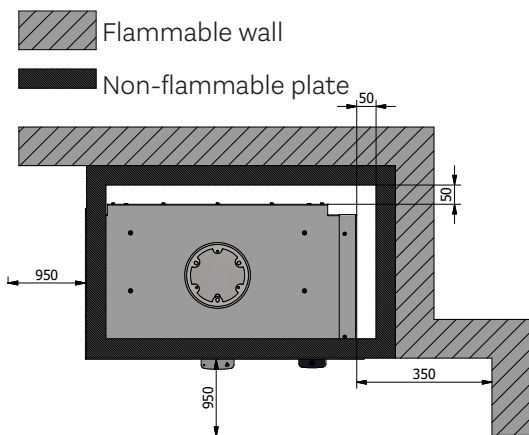

DISTANCE FROM	DISTANCE IN MM
Furniture to door	950
Furniture to side glass	950
Internal distance to cabinet	50
Ceiling to door top edge	1000
Ceiling from convection opening	500
Floor to door bottom edge	300
Flammable at side of door	350

INSTALLATION DISTANCE TO COMBUSTIBLE MATERIAL UN-INSULATED CHIMNEY

INSTALLATION DISTANCE: 600-2

A non-combustible plate must be fitted directly above the convection opening, so that "standing" hot air does not occur above the convection opening. This is done to protect the ceiling and direct the hot air out of the cassette.

The insulated part of the chimney must pass through the non-combustible board!

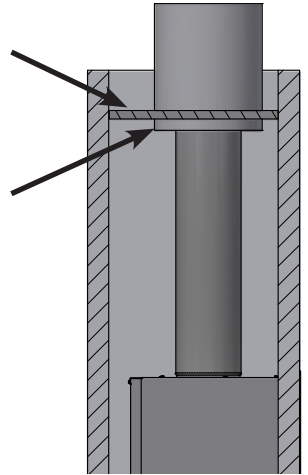

UK

When using an uninsulated chimney, a cavity of 50 mm must be created with stagnant air between the built-in box and the combustible wall before the safety distances apply.

When an uninsulated chimney is used, the three convection openings must be opened. see the section: Additional convection openings

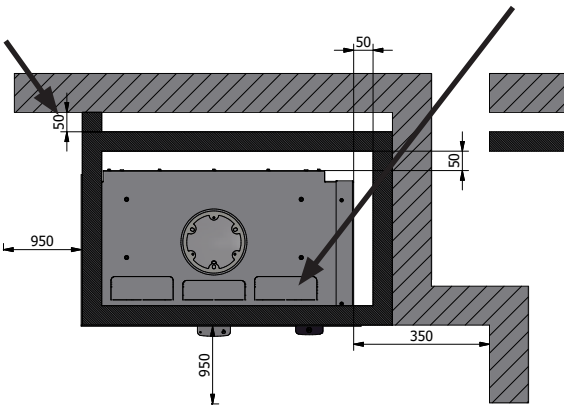

DISTANCE FROM	DISTANCE IN MM
Furniture to door	950
Furniture to side glass	950
Internal distance to cabinet	50
Ceiling to door top edge	1000
Ceiling from convection opening	500
Floor to door bottom edge	300
Flammable at side of door	350
Cavity behind built-in box	50

INSTALLATION DISTANCE: 600-2

If the cabinet is submerged into the wall, the first 175mm of the side wall must be made of non-combustible plate.

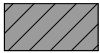

Flammable wall



Non-flammable plate

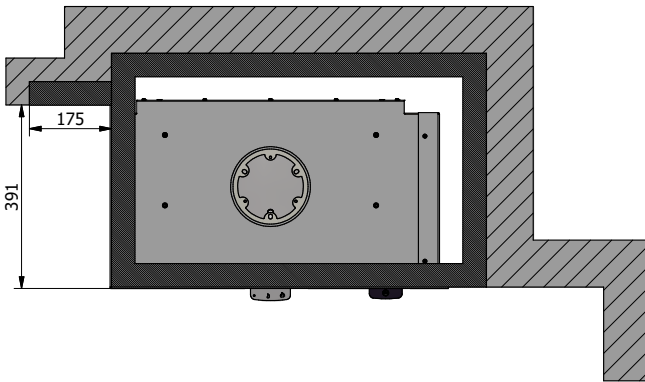

UK

INSTALLATION DIMENSIONS: 600-3

Applies to installations made from non-flammable panels.

Cavity dimensions (height x width) min. 615 x 678 x 375 mm

A fireplace insert may never be installed in a cavity that is tight, since steel expands when heated.

The minimum area for convection air above and below the fireplace insert can be distributed for several cavities.

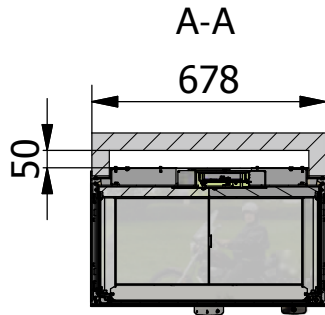
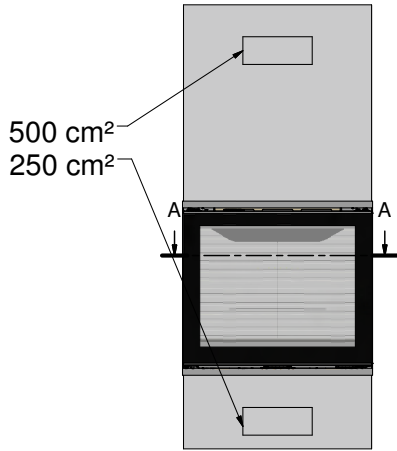
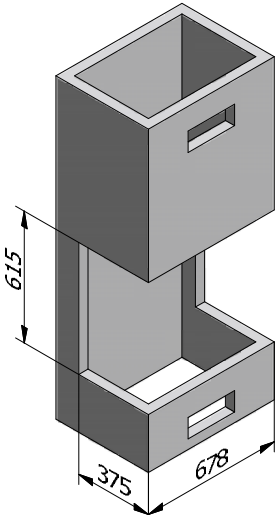

INSTALLATION DISTANCE TO COMBUSTIBLE MATERIAL INSULATED CHIMNEY

INSTALLATION DISTANCE: 600-3

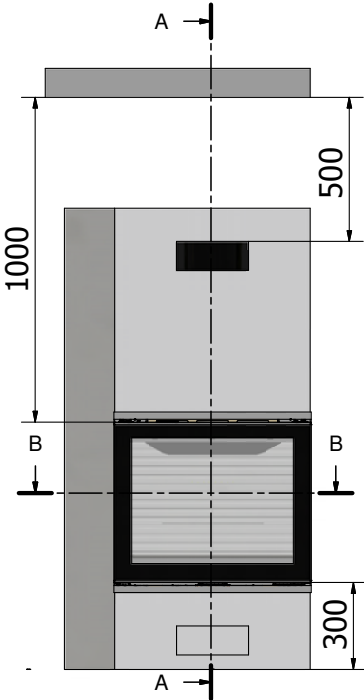

A non-flammable panel must be fitted directly above the convection opening so that “standing” hot air does not develop above the convection opening. This is done to protect the ceiling and to transport the heat out of the fireplace insert.

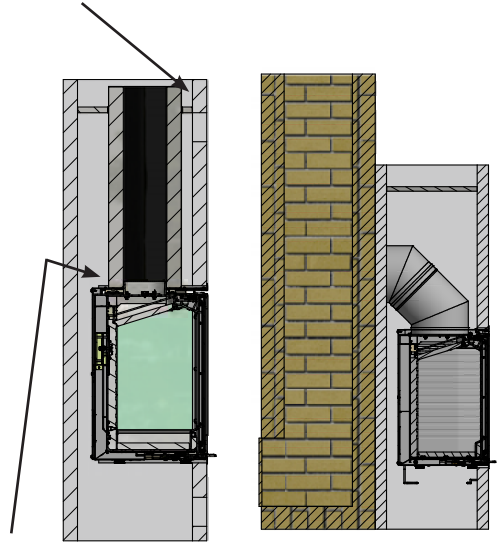

The insulated part of the chimney must extend all the way down to the flue spigot. Also applies if a bended pipe is used into an existing chimney (see drawing)

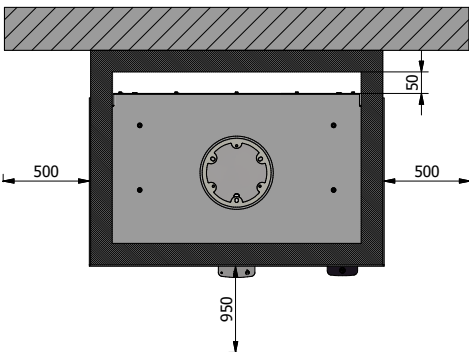
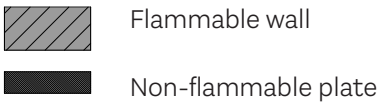

DISTANCE FROM	DISTANCE IN MM
Furniture to door	950
Furniture to side glass	500
Internal distance to cabinet	50
Ceiling to door top edge	1000
Ceiling from convection opening	500
Floor to door bottom edge	300

INSTALLATION DISTANCE TO COMBUSTIBLE MATERIAL UN-INSULATED CHIMNEY

INSTALLATION DISTANCE: 600-3

A non-combustible plate must be fitted directly above the convection opening, so that "standing" hot air does not occur above the convection opening. This is done to protect the ceiling and direct the hot air out of the cassette.

The insulated part of the chimney must pass through the non-combustible board!

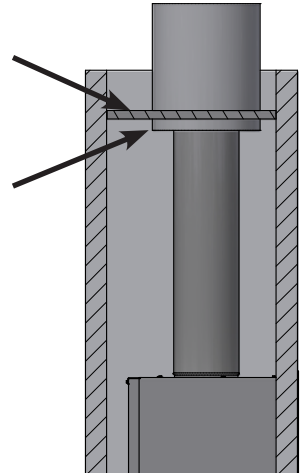

When using an uninsulated chimney, a cavity of 50 mm must be created with stagnant air between the built-in box and the combustible wall before the safety distances apply.

When an uninsulated chimney is used, the three convection openings must be opened. see the section: Additional convection openings

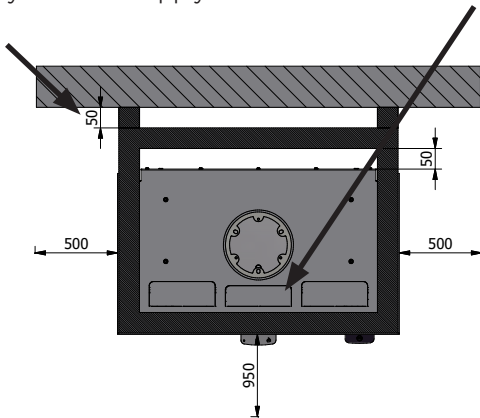

- Flammable wall
- Non-flammable plate

DISTANCE FROM	DISTANCE IN MM
Furniture to door	950
Furniture to side glass	500
Internal distance to cabinet	50
Ceiling to door top edge	1000
Ceiling from convection opening	500
Floor to door bottom edge	300
Cavity behind built-in box	50

INSTALLATION DISTANCE: 600-3

If the cabinet is submerged into the wall, the first 175mm of the side wall must be made of non-combustible plate.

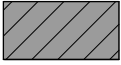

Flammable wall



Non-flammable plate

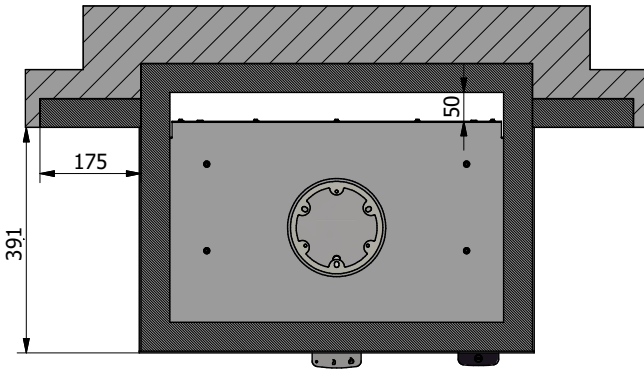

UK

ADJUSTABLE FEET

The height and straightness of the stove can be adjusted from inside the stove after the stove is placed, by removing the two bottom Skamol plates, now the four Adjustable feet can be adjusted with a 4mm Allen key.

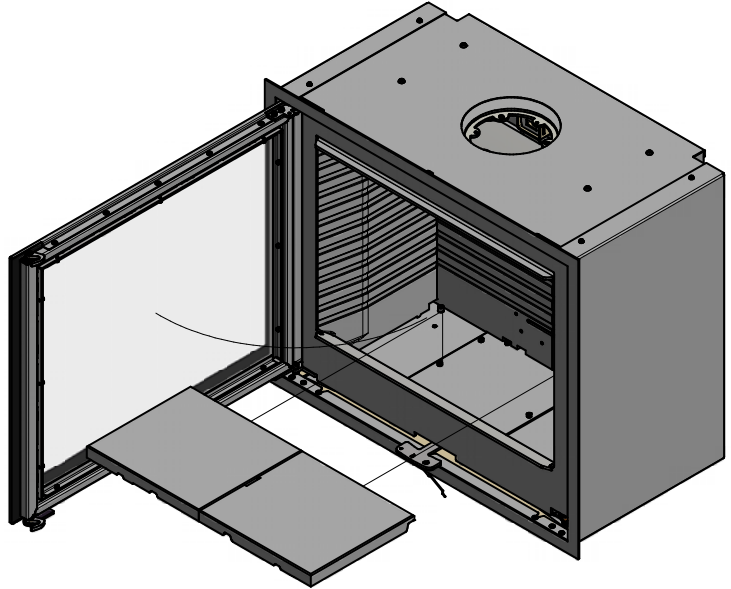

Adjustable feet

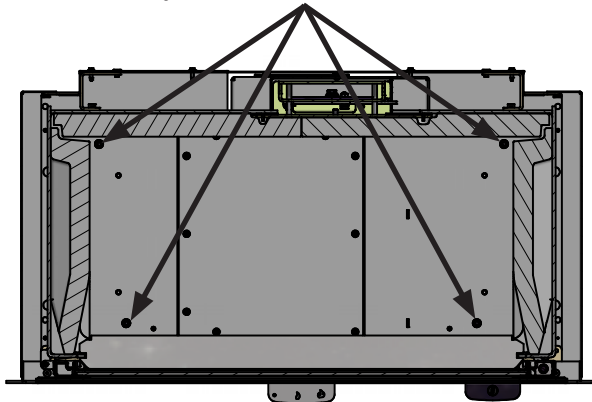

SERVICE HATCH

There is access to the air damper handle and air damper wire through the service hatch at the bottom of the combustion chamber.

Remove the Skamol plates from the combustion chamber and remove the screws from the service plate with a 4mm Allen key. There is now access to the damper handle and the damper wire under the combustion chamber.

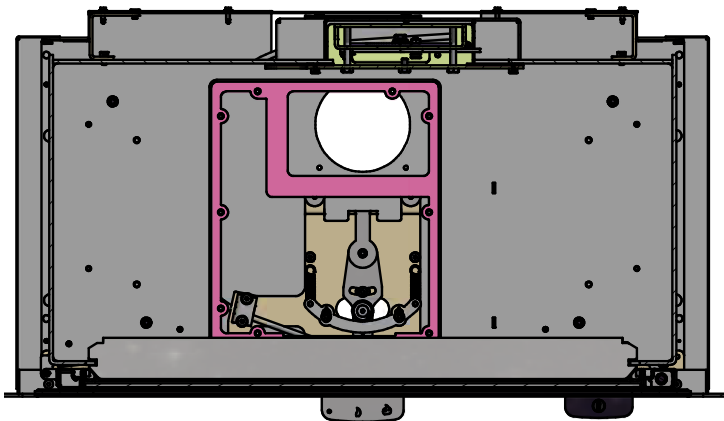
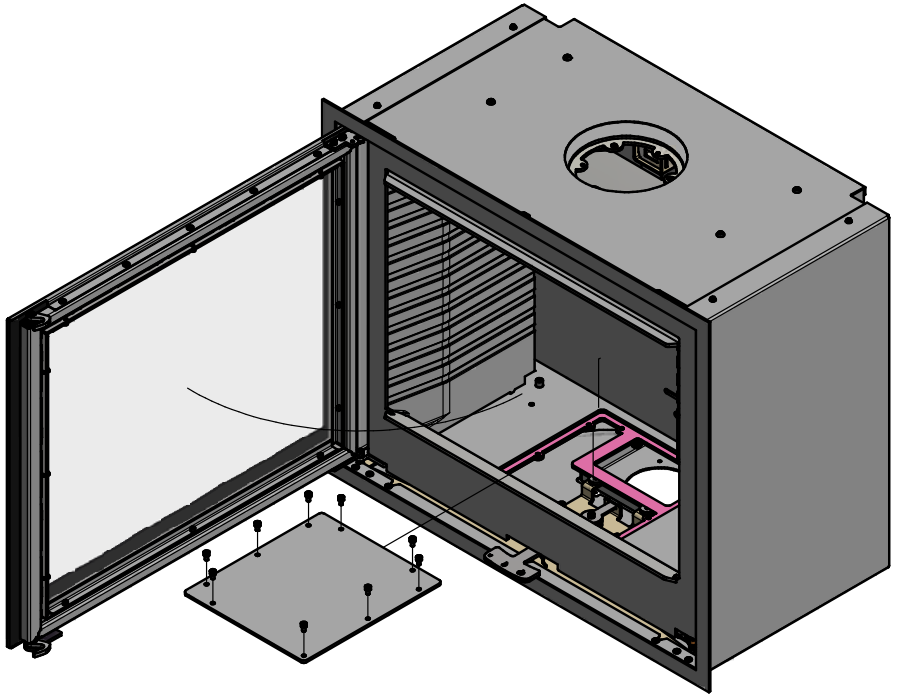

HEAT DISTRIBUTOR

By installing a heat distributor unit above the fireplace insert, heat can be 'transported' to other rooms.

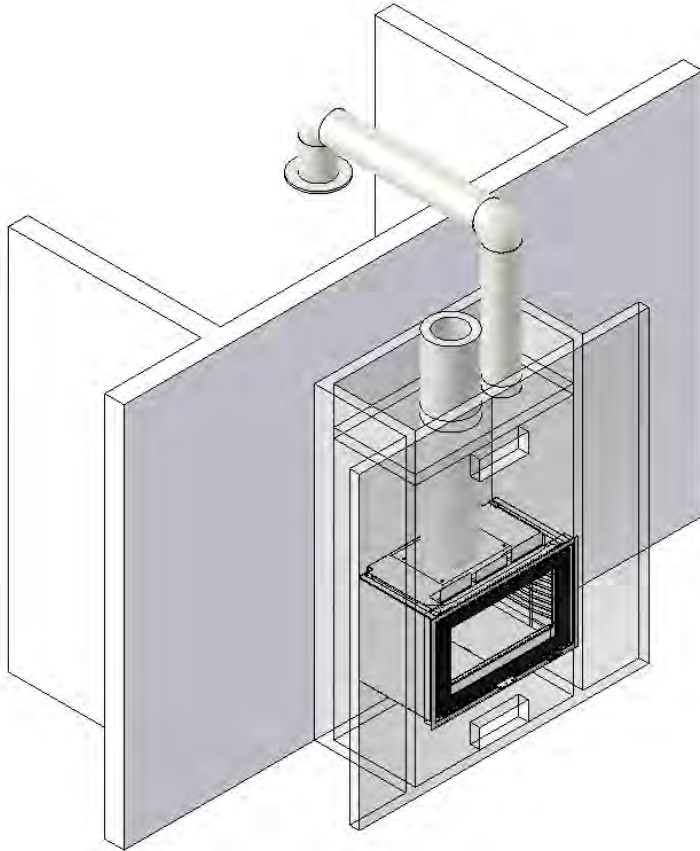

UK

EXTERNAL AIR CONNECTION
- AIRSYSTEM

All RAIS/ATTIKA fireplace inserts can have an external air connection for combustion. We call this external air supply AirSystem. The system can be connected to the underside or the rear of the fireplace insert.

INSTALLING AN AIR KIT ON THE UNDERSIDE

Fit the spigot (1) using the four M5 screws (4) and secure the flexible hose (3) using the hose clamp (2).

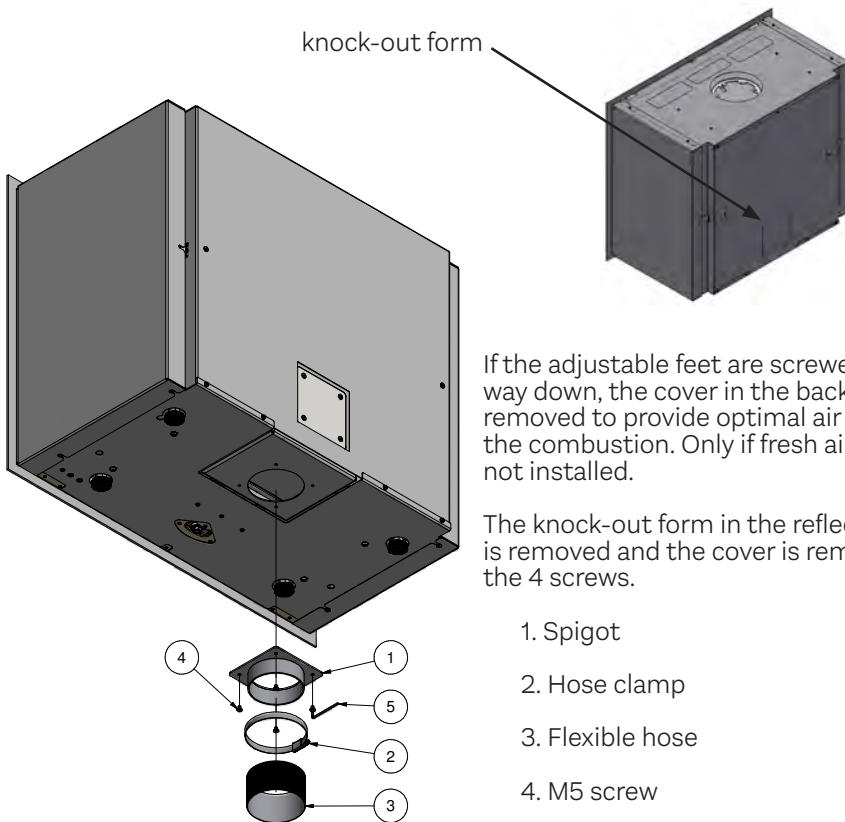

If the adjustable feet are screwed all the way down, the cover in the back can be removed to provide optimal air supply for the combustion. Only if fresh air supply is not installed.

The knock-out form in the reflector plate is removed and the cover is removed with the 4 screws.

1. Spigot
2. Hose clamp
3. Flexible hose
4. M5 screw
5. Allen key - 3 mm

INSTALLING AN AIR KIT ON THE REAR SIDE

Remove the cover on the rear side of the fireplace insert and detach the cover plate (6) using a 3 mm Allen key (5).

Re-fit the cover plate to the underside of the fireplace insert using the four M5 screws (4) ensuring that the air box is sealed.

Fit the spigot (1) on the rear of the fireplace insert and secure the flexible hose (3) using the hose clamp (2).

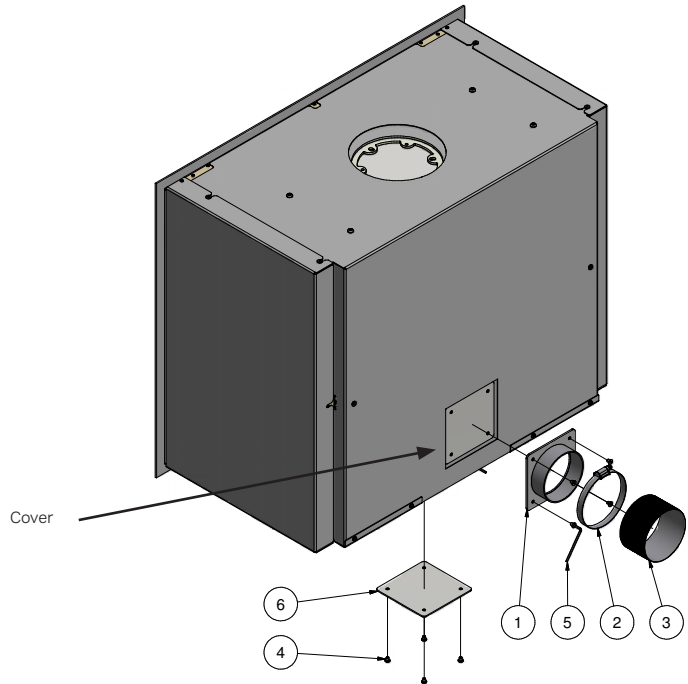

1. Spigot
2. Hose clamp
3. Flexible hose
4. M5 screw
5. Allen key - 3 mm
6. Cover plate

FITTING THE FLOOR PLATE

RAIS/ATTIKA supply elegant floor plates made from hardened glass that are designed for the shape of the fireplace insert. Floor plates can be purchased separately. The floor plate is simply pushed in against the fireplace insert, which allows for occasional cleaning under the plate.

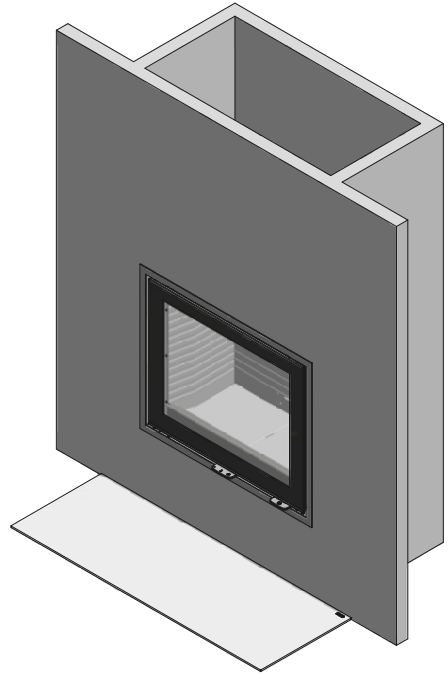

LUBRICATING HINGES

The fireplace must be lubricated regularly using the four moving parts on the lock and hinges (see image). Use heat-resistant oil.

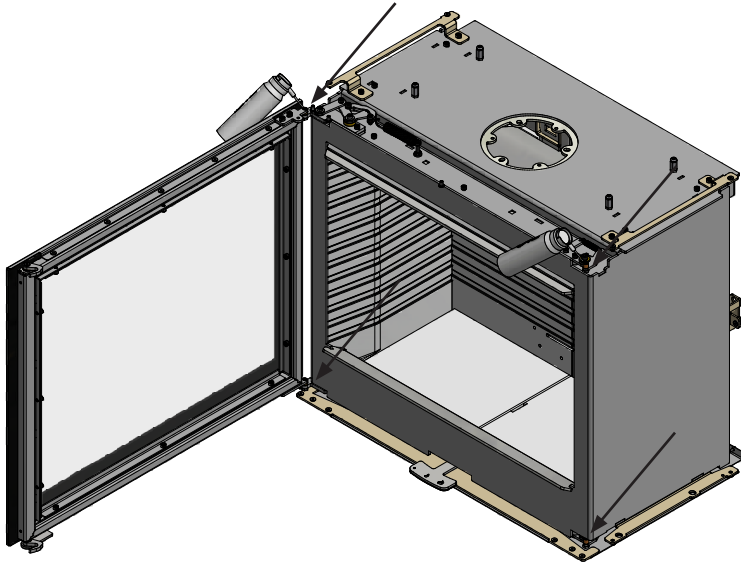

UK

REMOVING THE COMBUSTION CHAMBER LINING

The combustion chamber lining protects the body of the fireplace insert from the heat from the fire. The large differences in temperature can lead to cracks in the combustion chamber lining. This will not affect the functionality of the fireplace insert. The lining will only need be replaced after several years of use when it begins to disintegrate. The liner panels are simply placed in position by hand and can easily be replaced by you or your dealer.

Procedure to remove the combustion chamber lining:

1. Remove the flue panel (1) by pushing the front up and pulling forward, so that the rear end becomes free of the vertical panels. The flue panel can now be carefully removed.
2. Remove the base panel (2).
3. Loosen the side panels by turning the end of the panel in towards the fireplace's centre. Next, carefully remove.
4. Remove the rear panels (4) by removing the lock in the top of the panels. The panels are now loose and can be removed.
5. Panels (5) and (6) are located under the turbo plate and are not normally removed.

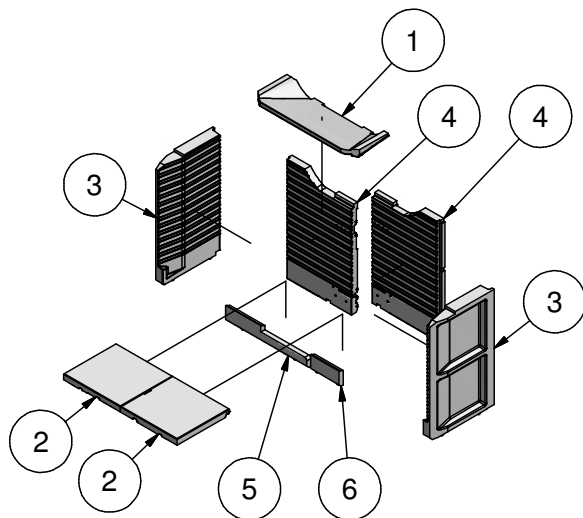

CLEANING THE FLUE

Remove the flue panel by pushing the front up and pulling forward, so that the rear end becomes free of the vertical panels. The flue panel can now be carefully removed.

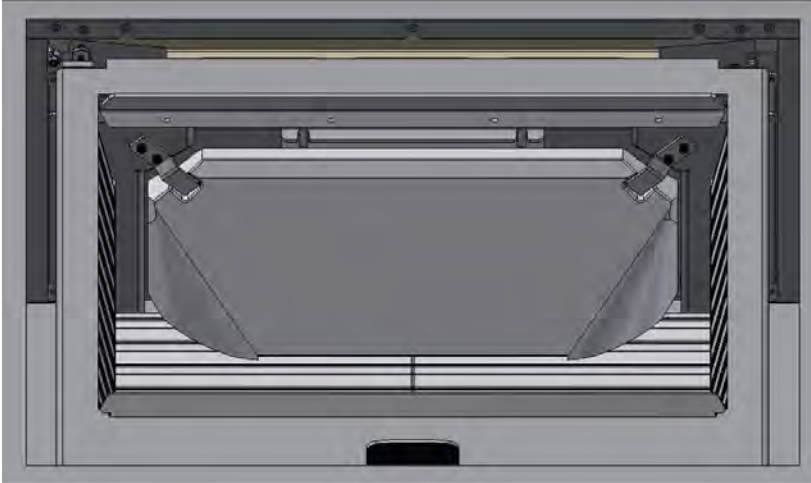

Remove the steel baffle by pushing the rear end up, freeing it from the bracket.

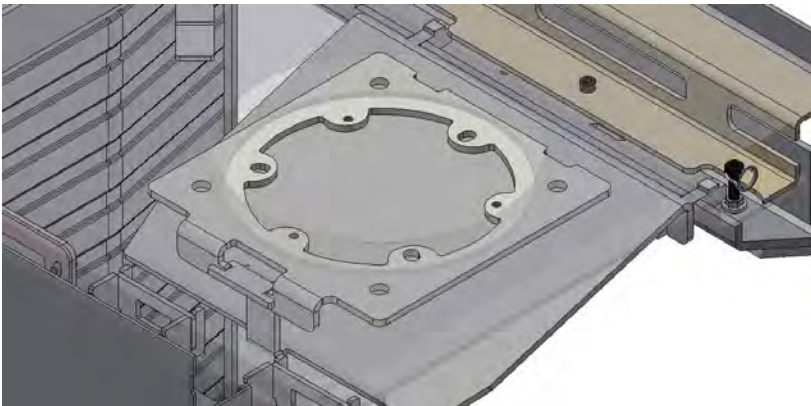

CLEANING THE FLUE

Push the baffle back sufficiently to free it from the bearing surfaces in the front of the fireplace insert.
Fit the parts in reverse order.

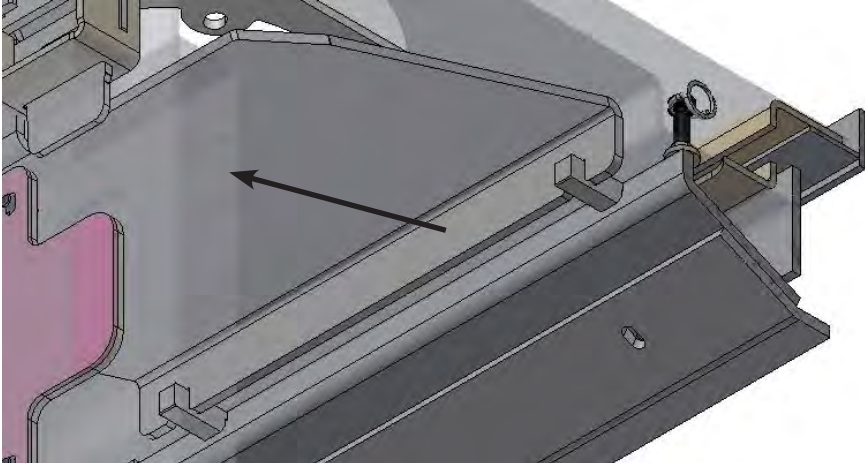

OPENING OF EXTRA CONVECTION VENTS

To provide better air circulation and a cooler wall above the insert, we recommend that the extra convection openings be opened before the installation is completed. The three flaps are bent up to 90°

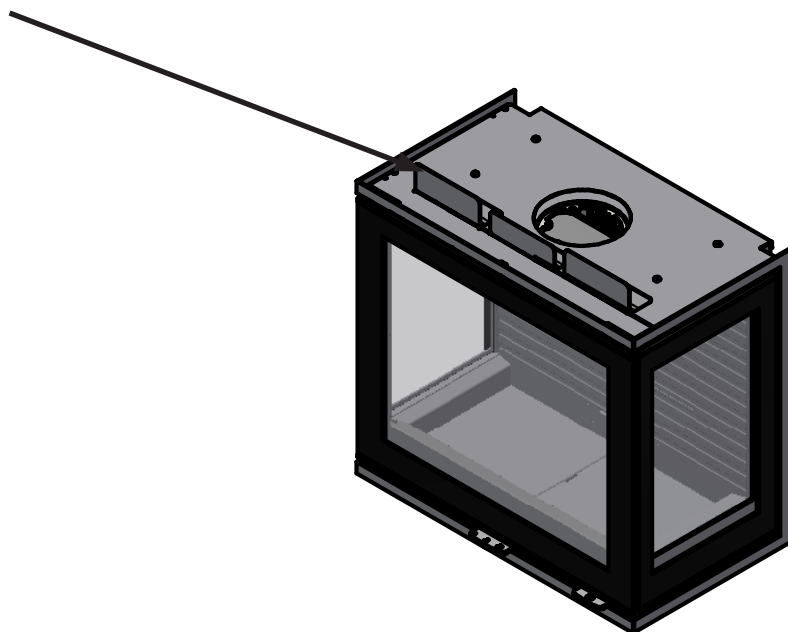

OPENING OF ADDITIONAL CONVECTION OPENINGS AFTER INSTALLATION

After installation, the additional convection openings can be opened using a special tool 11-0000-040118 (can be purchased separately)

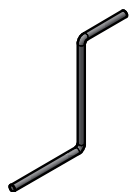

Step 1

Open the door.

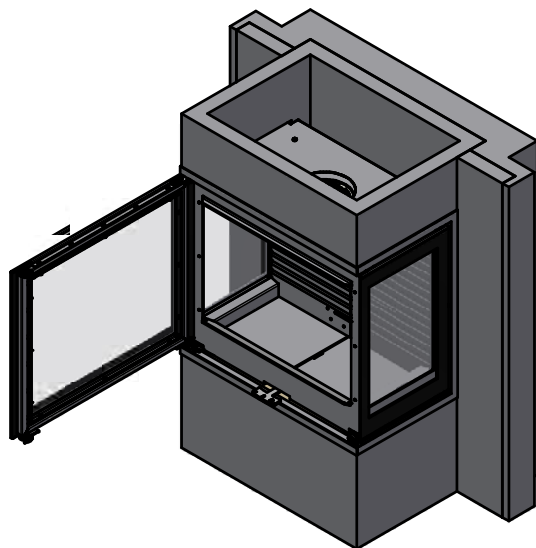

Step 2

Hold the tool approx. 25mm from the front edge of the combustion chamber.

The short end of the tool is inserted under the convection top. Turn the tool 90° down and the flap will bend up.

11-0000-040118

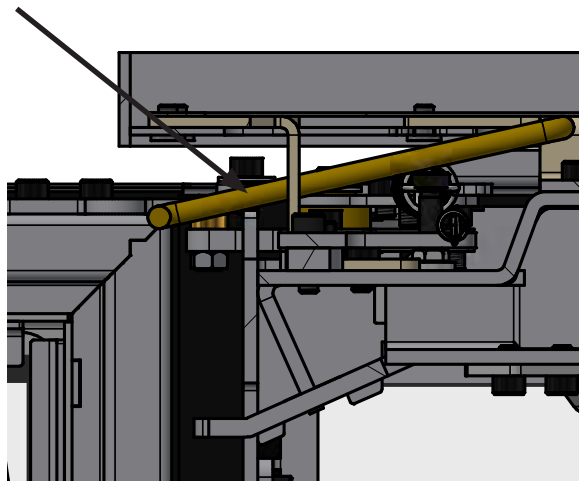
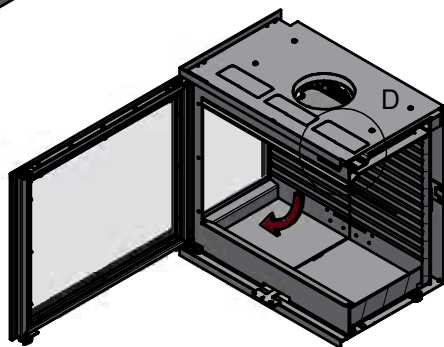

Step 3

Pull the tool to fully open the flap.

Repeat the procedure for the other two flaps.

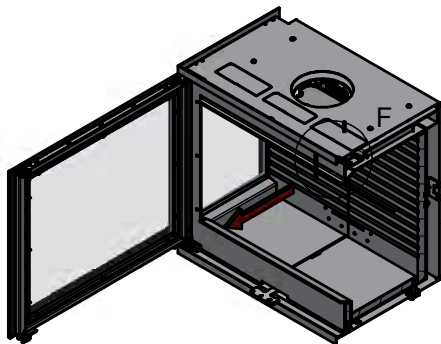

U
K

When building in bricks, it is necessary to remove parts of the lower bricks, to make room for bending the convection flaps up.
see picture

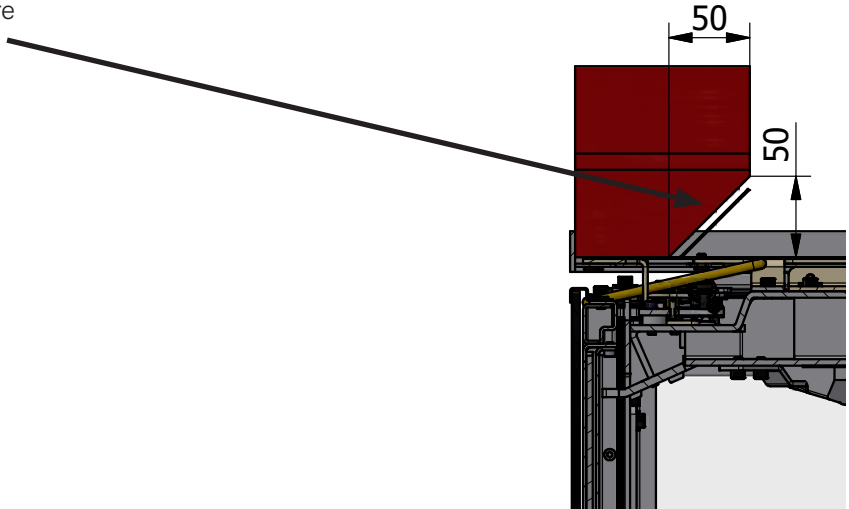

UK

SPAREPART DRAWING

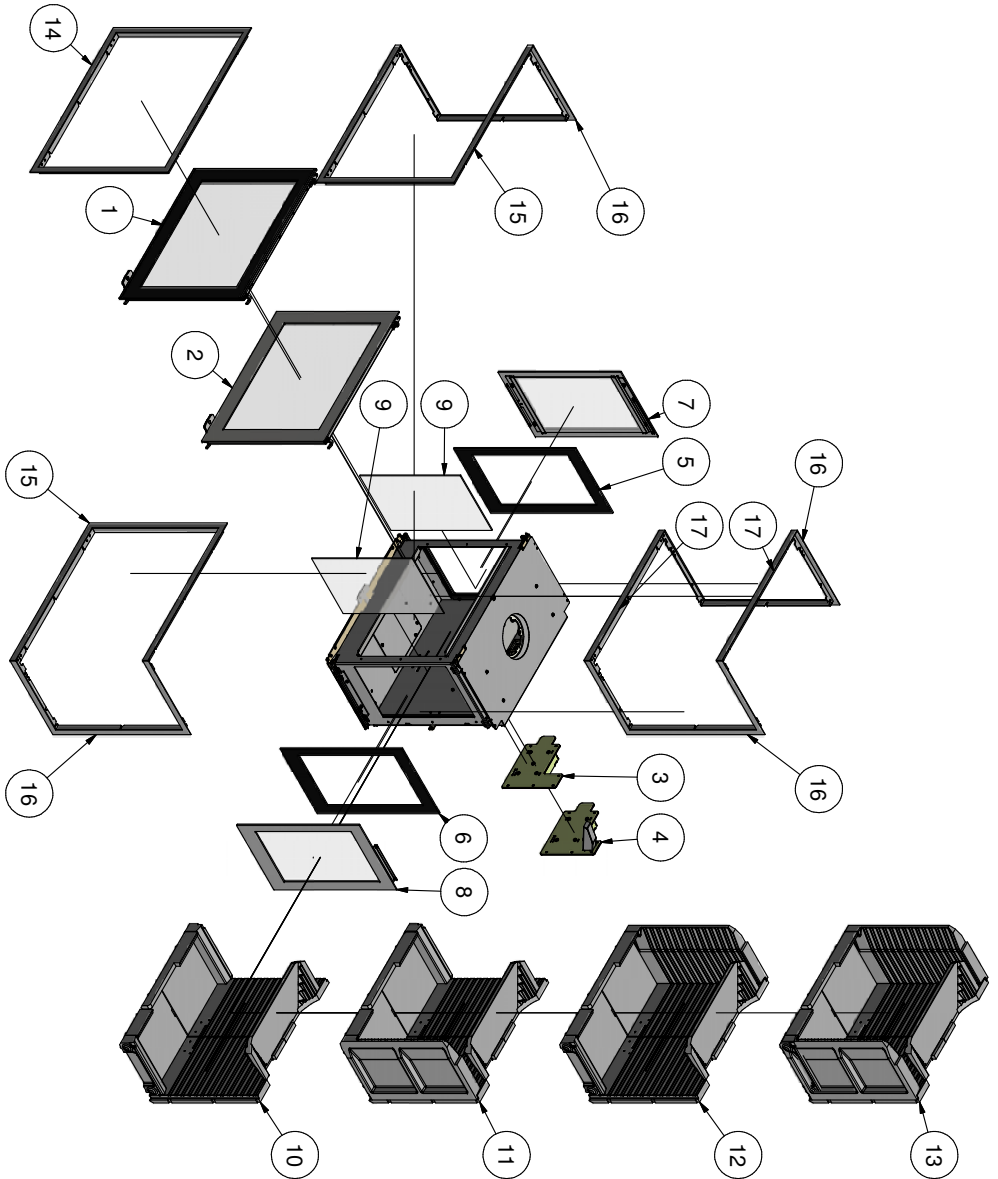

UK

SPAREPART LISTE

xx: optional color code

POS.	PCS.	ITEM NUMBER	TITLE
1	1	11-0000-100190	GLASS DOOR
2	1	11-0000-100290	CLASSIC DOOR
3	1	1711790	AIRDAMPER
4	1	1710990	AIRDAMPER CLEVERAIR
5	1	11-0000-5003	OUTER GLASS LEFT SIDE
6	1	11-0000-5004	OUTER GLASS RIGHT SIDE
7	1	11-0000-2601	CLASSIC SIDE PANEL LEFT
8	1	11-0000-2602	CLASSIC SIDE PANEL RIGHT
9	2	11-0000-5005	INNER GLASS FOR BODY - IR COATED
10	1	11-0000-2201	SKAMOL SET - 3G MODEL
11	1	11-0000-2202	SKAMOL SET - LEFT MODEL
12	1	11-0000-2202	SKAMOL SET - RIGHT MODEL
13	1	11-0000-2202	SKAMOL SET - FRONT MODEL
14	1	11-0000-140106XX	COVER FRONT MODEL
15	1	11-0000-140107XX	COVER - CORNER MODEL
16	1	11-0000-140102XX	COVER SIDE
17	2	11-0000-140101XX	FRONT COVER

UK

DECLARATION OF PERFORMANCE

UK DECLARATION OF PERFORMANCE

Regulation (EU) 305/2011 No. 0001 — CPR-2013/07/01

No.: 11



- | | | |
|---|--|---|
| 1. Unique identification code of the product-type | RAIS 600 Front Model
RAIS 600 Right Model
RAIS 600 Left Model
RAIS 600 3G Model | Attko R 600 Front Model
Attko R 600 Right Model
Attko R 600 Left Model
Attko R 600 3G Model |
| 2. Type | Inset appliance burning solid fuel without hot water supply | |
| 3. Intended use | Domestic room heater | |
| 4. Manufacturer | RAIS A/S
Industrivej 20, Vangen
DK-9900 Frederikshavn,
Denmark | Telephone +45 98 47 90 33
Telefax +45 98 47 92 91
Webmail kundeservice@rais.dk
Homepage www.rais.com |
| 5. Authorised representative | n/a | |
| 6. System of assessment AVCP | System 3 | |
| 7. Notified body | The notified laboratory Danish Technological Institute - Identification no. 1235 Teknologiparken, Kongsvang Allé 29, DK-8000 Århus C | |
- performed the determination of the product type on the basis of type testing under system 3 and issued test report
- a. 300-ELAB-2431-EN
8. Declared performance Harmonized technical specification: EN 13229:2001/A2:2004/AC:2007

Essential characteristics		Performance		
Fire safety		<ul style="list-style-type: none"> Insulated flue 50 mm Skamotec 225 non-combustible panel board Distances are measured externally on the built-in box		
Reaction to fire	A1	RAIS 600 Front Model	RAIS 600 Right Model RAIS 600 Left Model	RAIS 600 3G Model
Distance to combustible materials	rear	0	0	0
Minimum distances [mm] <i>For other installation or wall settings see instruction manual</i>	sides	350	950	500
	ceiling	1000	1000	1000
	Front	1100	950	950
	Floor	300	300	300
Risk of burning fuel falling out	Pass			
OGC (mg/Nm ³ rel. 13 Vol-% O ₂)	54			
CO-emission of combustion products	0.0915 % / 1144 mg/Nm ³			
NO _x (mg/Nm ³ rel. 13 Vol-% O ₂)	69			
Dust mg/Nm ³ at (rel. 13 Vol-% O ₂)	5			
Surface temperature	Pass			
Electrical safety	NPD			
Cleanability	Pass			
Maximum operating pressure	- bar			
Flue gas temperature T at nominal heat output	308 °C			
Mechanical resistance (to carry a chimney/flue)	NPD			
Thermal output				
Nominal heat output	5,8 kW			
Room heating output	5,8 kW			
Water heating output	- kW			
Energy efficiency η_f	78 %			
Seasonal Efficiency $\eta_{s,01}$	66 %			

9. The performance of the product identified in points 1 and 2 is in conformity with the declared performance in point 8. This declaration of performance is issued under the sole responsibility of the manufacturer identified in point 4.

Signed for and on behalf of the manufacturer by:

John Engell Nielsen, R&D Manager

Place FREDERIKSHAVN, DENMARK

Signature

Date 31-03-2022



DANAK
TEST Reg.nr. 300



**TEKNOLOGISK
INSTITUT**

Teknologiparken
Kongsvang Allé 29
DK-8000 Aarhus C
Phone +45 72 20 10 00

Info@teknologisk.dk

TEKNOLOGISK INSTITUT

Akkrediteret prøvningsorgan, DANAK-akkreditering nr. 300
Notificeret prøvningsorgan med ID-nr. 1235

Prøvningsattest III

Uddrag af rapport nr. 300-ELAB-2431-EN og 300-ELAB-2431-NS

Emne: Pejseindsatse; Rais 600 Front eller Rais 600 Classic Front

Rekvirent: Rais A/S

Industrivej 20, DK - 9900 Frederikshavn

Procedure:

X	Prøvning efter DS/EN13240/A2:2004
X	Prøvning efter NS3058-1 & -2 (partikelmåling)
X	Emissionsmåling af støv og OGC

Prøvningsresultater

Akkrediteret prøvning af brændeovn iht. EN 13240 er foretaget med brænde der påfyres manuelt, og følgende resultater blev opnået:

Nominel ydelse:	5,8 kW
CO-emission:	0,09 % - henført til 13 % O ₂
Virkningsgrad:	76 %
Røggastemperatur:	306 °C
Afstand til bagvæg:	- se opstillingsvejledning
Afstand til sidevæg:	- se opstillingsvejledning

Emissioner iht. NS 3058 og/eller CEN/TS 15883:

Partikler efter NS 3058:	2,11 g/kg (tørstof) middelværdi (krav: ≤4)
Partikler efter NS 3058:	2,84 g/kg (tørstof) maksimalt (krav: ≤8)
OGC efter CEN/TS 15883:	54 mgC/Nm ³ ved 13% O ₂ (krav: ≤120)
Støv efter EN 16510-1:	5 mg/Nm ³ ved 13% O ₂ (krav: ≤30)

Bemærk venligst, at de oplyste værdier er et uddrag af prøvningsrapporten.
For yderligere oplysninger henvises til prøvningsrapporten, se nummer ovenfor.

Aarhus, den 16. oktober 2019  Kim Sig Andersen Titel	Skorstensfejerpåtegning
--	-------------------------

På baggrund af ovennævnte emissioner attesteres det hermed, at fyringsanlægget opfylder emissionskravene i bilag 1 til Bekendtgørelse nr. 49 af 16/01-2018 om regulering af luftforurening fra fyringsanlæg til fast brændsel under 1 MW.



**TEKNOLOGISK
INSTITUT**

Teknologiparken
Kongsvang Allé 29
DK-8000 Aarhus C
Phone +45 72 20 10 00

Info@teknologisk.dk

TEKNOLOGISK INSTITUT

Akkrediteret prøvningsorgan, DANAK-akkreditering nr. 300
Notificeret prøvningsorgan med ID-nr. 1235

Prøvningsattest III

Uddrag af rapport nr. 300-ELAB-2431-EN og 300-ELAB-2431-NS

Emne: Pejseindsatse; Rais 600 eller Rais 600 Classic som Right, Left, 3 Side modeller

Rekvirent: Rais A/S
Industrivej 20, DK – 9900 Frederikshavn

Procedure:	<input checked="" type="checkbox"/>	Prøvning efter DS/EN13240/A2:2004
	<input checked="" type="checkbox"/>	Prøvning efter NS3058-1 & -2 (partikelmåling)
	<input checked="" type="checkbox"/>	Emissionsmåling af støv og OGC

Prøvningsresultater

Akkrediteret prøvning af brændeovn iht. EN 13240 er foretaget med brænde der påfyres manuelt, og følgende resultater blev opnået:

Nominel ydelse: 5,8 kW
CO-emission: 0,09 % - henført til 13 % O₂
Virkningsgrad: 76 %
Røggastemperatur: 306 °C
Afstand til bagvæg: - se opstillingsvejledning
Afstand til sidevæg: - se opstillingsvejledning

Emissioner iht. NS 3058 og/eller CEN/TS 15883:

Partikler efter NS 3058: 2,11 g/kg (tørstof) middelværdi (krav: ≤4)
Partikler efter NS 3058: 2,84 g/kg (tørstof) maksimalt (krav: ≤8)
OGC efter CEN/TS 15883: 54 mgC/Nm³ ved 13% O₂ (krav: ≤120)
Støv efter EN 16510-1: 5 mg/Nm³ ved 13% O₂ (krav: ≤30)

Bemærk venligst, at de oplyste værdier er et uddrag af prøvningsrapporten.
For yderligere oplysninger henvises til prøvningsrapporten, se nummer ovenfor.

Aarhus, den 4. oktober 2019 Kim Sig Andersen Titel	Skorstensfejerpåtegning
--	-------------------------

På baggrund af ovennævnte emissioner attesteres det hermed, at fyringsanlægget opfylder emissionskravene i bilag 1 til Bekendtgørelse nr. 49 af 16/01-2018 om regulering af luftforurening fra fyringsanlæg til fast brændsel under 1 MW.

THE CLEAN AIR ACT 1993 AND SMOKE CONTROL AREAS

UNDER THE CLEAN AIR ACT LOCAL AUTHORITIES MAY DECLARE THE WHOLE OR PART OF THE DISTRICT OF THE AUTHORITY TO BE A SMOKE CONTROL AREA. IT IS AN OFFENCE TO EMIT SMOKE FROM A CHIMNEY OF A BUILDING, FROM A FURNACE OR FROM ANY FIXED BOILER IF LOCATED IN A DESIGNATED SMOKE CONTROL AREA. IT IS ALSO AN OFFENCE TO ACQUIRE AN "UNAUTHORISED FUEL" FOR USE WITHIN A SMOKE CONTROL AREA UNLESS IT IS USED IN AN "EXEMPT" APPLIANCE ("EXEMPTED" FROM THE CONTROLS WHICH GENERALLY APPLY IN THE SMOKE CONTROL AREA).

IN ENGLAND APPLIANCES ARE EXEMPTED BY PUBLICATION ON A LIST BY THE SECRETARY OF STATE IN ACCORDANCE WITH CHANGES MADE TO SECTIONS 20 AND 21 OF THE CLEAN AIR ACT 1993 BY SECTION 15 OF THE DEREGULATION ACT 2015. IN SCOTLAND APPLIANCES ARE EXEMPTED BY PUBLICATION ON A LIST BY SCOTTISH MINISTERS UNDER SECTION 50 OF THE REGULATORY REFORM (SCOTLAND) ACT 2014. SIMILARLY, IN NORTHERN IRELAND APPLIANCES ARE EXEMPTED BY PUBLICATION ON A LIST BY THE DEPARTMENT OF AGRICULTURE, ENVIRONMENT AND RURAL AFFAIRS UNDER SECTION 16 OF THE ENVIRONMENTAL BETTER REGULATION ACT (NORTHERN IRELAND) 2016. IN WALES APPLIANCES ARE EXEMPTED BY REGULATIONS MADE BY WELSH MINISTERS.

THE SECRETARY OF STATE FOR ENVIRONMENT, FOOD AND RURAL AFFAIRS HAS POWERS UNDER THE ACT TO AUTHORIZE SMOKELESS FUELS OR EXEMPT APPLIANCES FOR USE IN SMOKE CONTROL AREAS IN ENGLAND. IN SCOTLAND AND WALES THIS POWER RESTS WITH THE MINISTERS IN THE DEVOLVED ADMINISTRATIONS FOR THOSE COUNTRIES. SEPARATE LEGISLATION, THE CLEAN AIR (NORTHERN IRELAND) ORDER 1981, APPLIES IN NORTHERN IRELAND. THEREFORE IT IS A REQUIREMENT THAT FUELS BURNT OR OBTAINED FOR USE IN SMOKE CONTROL AREAS HAVE BEEN "AUTHORISED" IN REGULATIONS AND THAT APPLIANCES USED TO BURN SOLID FUEL IN THOSE AREAS (OTHER THAN "AUTHORISED" FUELS) HAVE BEEN EXEMPTED BY AN ORDER MADE AND SIGNED BY THE SECRETARY OF STATE OR MINISTER IN THE DEVOLVED ADMINISTRATIONS.

THE RAIS 600-1, 600-2 AND 600-3 HAVE BEEN RECOMMENDED AS SUITABLE FOR USE IN SMOKE CONTROL AREAS WHEN BURNING WOOD LOGS.

FUEL OVERLOADING

THE MAXIMUM AMOUNT OF FUEL SPECIFIED IN THIS MANUAL SHOULD NOT BE EXCEEDED, OVERLOADING CAN CAUSE EXCESS SMOKE.

REFUELLING ON TO A LOW FIRE BED

IF THERE IS INSUFFICIENT BURNING MATERIAL IN THE FIREBED TO LIGHT A NEW FUEL CHARGE, EXCESSIVE SMOKE EMISSION CAN OCCUR. REFUELLING MUST BE CARRIED OUT ONTO A SUFFICIENT QUANTITY OF GLOWING EMBERS AND ASH THAT THE NEW FUEL CHARGE WILL IGNITE IN A REASONABLE PERIOD. IF THERE ARE TOO FEW EMBERS IN THE FIRE BED ADD SUITABLE KINDLING TO PREVENT EXCESS SMOKE.

DAMPERS LEFT OPEN

OPERATION WITH THE AIR CONTROL OR APPLIANCE DAMPERS OPEN CAN CAUSE EXCESS SMOKE. THE APPLIANCE MUST NOT BE OPERATED WITH AIR CONTROLS, APPLIANCE DAMPERS OR DOOR LEFT OPEN EXCEPT AS DIRECTED IN THE INSTRUCTIONS.

OPERATION WITH DOOR LEFT OPEN

OPERATION WITH THE DOOR OPEN CAN CAUSE EXCESS SMOKE. THE APPLIANCE MUST NOT BE OPERATED WITH THE APPLIANCE DOOR LEFT OPEN EXCEPT AS DIRECTED IN THE INSTRUCTIONS.



RAIS[®]
ART  OF FIRE

RAIS A/S
Industrivej 20
DK-9900 Frederikshavn
Denmark
www.rais.com

attika
FEUERKULTUR

ATTIKA FEUER AG
Brunnmatt 16
CH-6330 Cham
Switzerland
www.attika.ch